

# High power HIGHBAY Lamp

**Model: BELLSTAR-195-X-2B (x denote LED color)**

**1. Applications:** Suitable for wet locations

**2. Mechanical specification:**

Housing: Aluminum, glass

Outline Dim:  $\Phi$  420\*398mm

Net Weight: about 12kg

Surface temperature:  $<65^{\circ}\text{C}$  (@ $T_a=25^{\circ}\text{C}$ )



**3.Environment Specification:**

Operation Temp:  $-30\sim+40^{\circ}\text{C}$

Humidity range: 10% ~ 90%

**4.Electric Specification:**

Input Voltage: 100-240Vac 47~63 Hz

LED Consumption: 170W

Power Consumption: 195W

**5. Optical performance:**

Color Temp: Cool White 5000~7000K&Warm White 2800K~3800K

CRI: Cool white $>70$  warm white $>80$

Beam Angle : 15,30,38° can select

**This spec is refer to 38Degree.**

Lighting Output Lumens: 14500lm@230V 50Hz 5000K

Intensity of illumination: 35500Lx@1 m distance 5000K 38°

2220Lx@4 m distance 5000K38°

555Lx@8m distance 5000K38°

246Lx@12 m distance 5000K38°

138Lx@16 m distance 5000K 38°

**6. Average life time:** 30,000 hours in min.

## 7. Dimension:

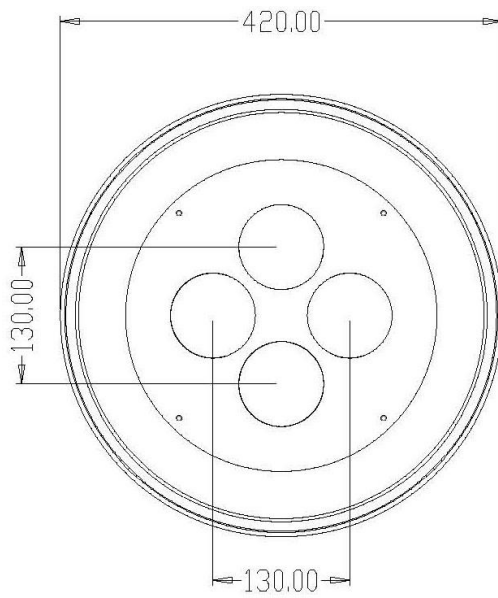
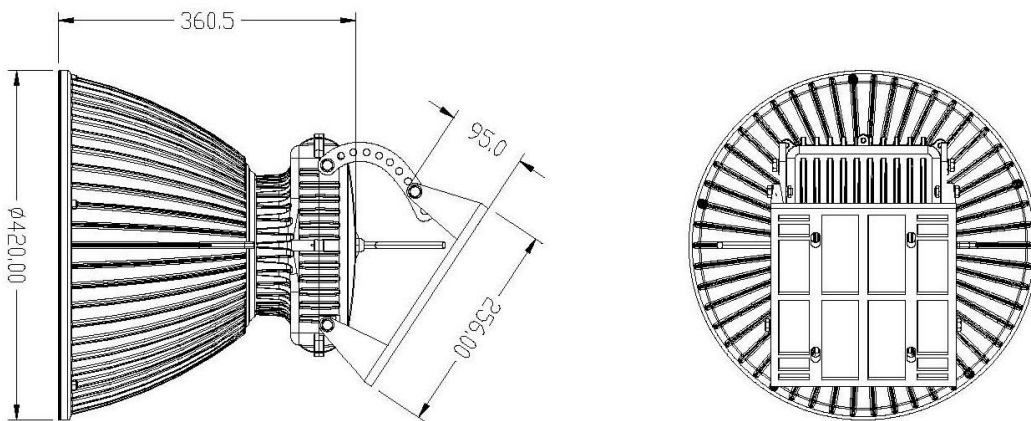
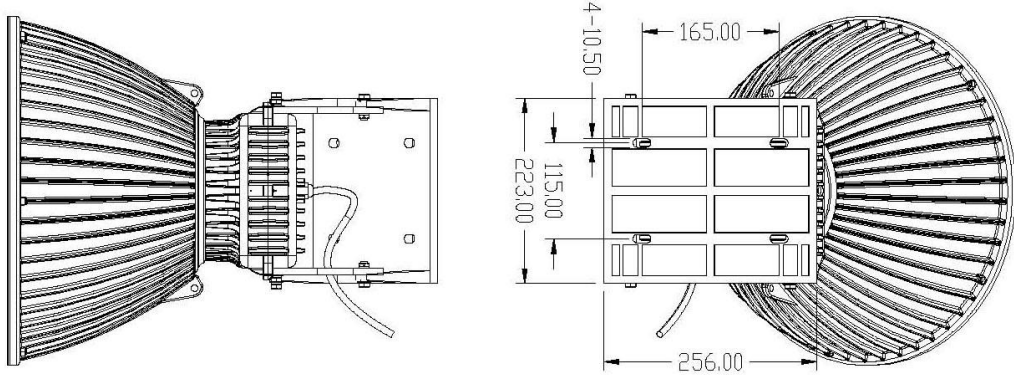

## 8. Test report

